



V300

COMMERCIAL VINYL SERIES









Swing Door | Fixed

 Product Material
uPVC Vinyl

 Frame Depth
3 1/4"

 Rating
Inswing: CW50*
Outswing: CW50*
Fixed: CW50*



 Design Pressure Inswing: 50 Outswing: 50 Fixed: 50	 U-Value* Inswing: 0.21 - 0.30# Outswing: 0.21 - 0.30# Fixed:
 Air Infiltration Inswing: <.30 Outswing: <.30 Fixed: <.30	 SHGC* Inswing: 0.09 - 0.24# Outswing: 0.09 - 0.24# Fixed:
 Water Resistance Inswing: Up to 7.5 Outswing: Up to 7.5 Fixed: Up to 7.5	 CRF* Inswing: 45-64# Outswing: 45-64# Fixed:
 OITC* Inswing: Outswing: Fixed:	 STC* Inswing: Outswing: Fixed:
<p>#- U-Value and SHGC ranges are NFRC certified based on I.G. combinations incorporating some or all the following: Low-E glass, clear glass, argon gas and/or air fill, and grids *-Contact Quaker for STC & OITC information</p>	

FEATURES:

- ▶ Extruded, architectural grade uPVC vinyl frame
- ▶ 1" insulating glass
- ▶ Inswing or Outswing single-panel operation
- ▶ Standard Widths: 2⁸, 3⁰, 3²
- ▶ Standard heights: 6⁸, 6¹⁰, 8⁰
- ▶ Max sizing: 48" x 96"
- ▶ Minimum sizing: 32" x 72"
- ▶ 2 5/8" threshold. Optional ADA threshold w/10" bottom rail
- ▶ Multi-point WHS hardware
- ▶ Butt hinges - 3 axis adjustability
- ▶ Keyed hardware option
- ▶ White or Sandstone uPVC vinyl
- ▶ Optional painted exterior (meets FGIA 615 finish)
- ▶ Textured laminate options for exterior and interior
- ▶ Fixed Transom and Sidelite

www.QuakerCommercialWindows.com

Information listed is deemed accurate as of date shown. Quaker Windows reserves the right to change or discontinue any product, feature or option without notice.

October, 2024 V5



V300

COMMERCIAL VINYL SERIES

Outswing
w/standard sill

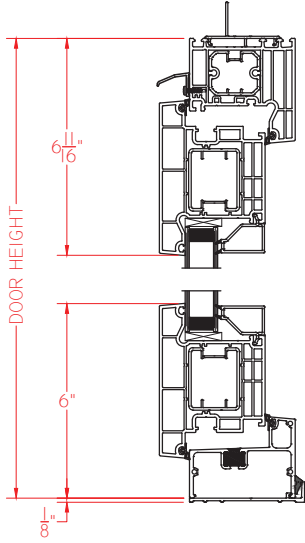

Outswing
w/ADA sill

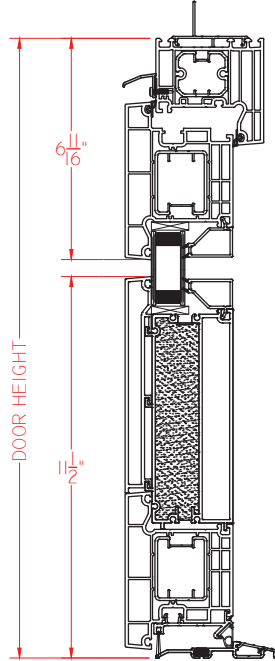

Inswing
w/standard sill

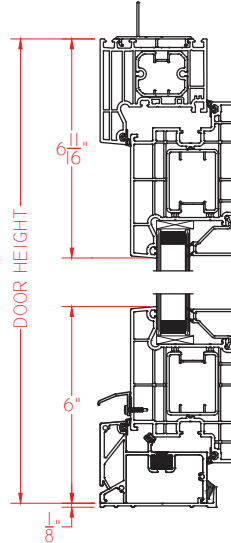

Inswing
w/ADA sill

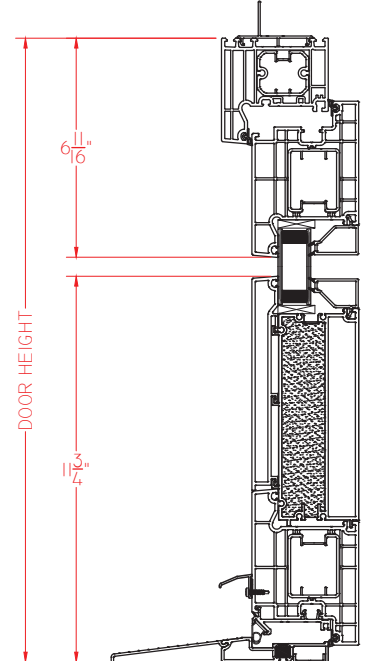

Outswing Models
(horizontal cross section)

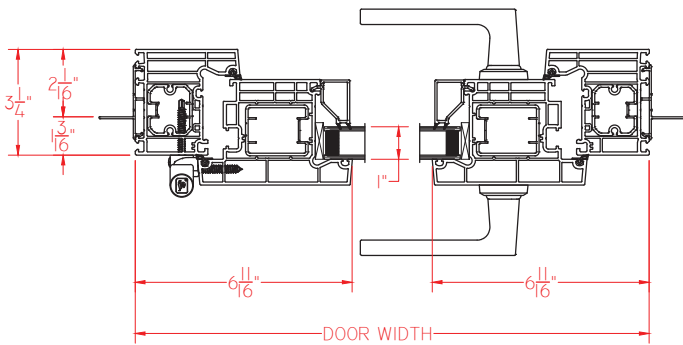

Inswing Models
(horizontal cross section)

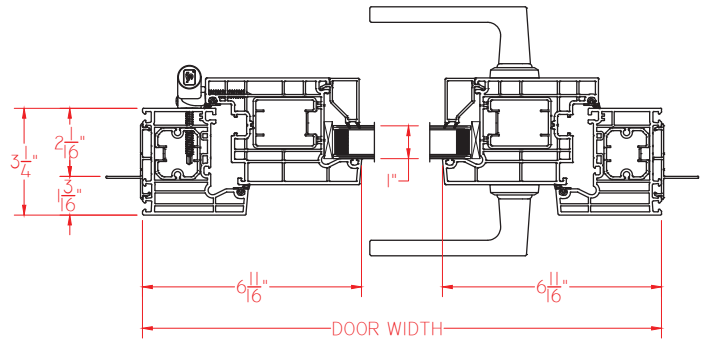

QuakerCommercialWindows.com
1-800-347-0438
Commercial@quakerwindows.com